

Overview

The GE EST iO64 intelligent life safety system offers the power of high-end intelligent processing in a configuration that delivers an uncomplicated solution for small to mid-sized applications. With intelligent detection, electronic addressing, automatic device mapping, optional Ethernet® connectivity, and a full line of easily-configured option cards and modules, this flexible system offers advanced features that benefit building owners and contractors alike.

The iO64 provides one Class B analog device loop that supports up to 64 device addresses, and two Class B Notification Appliance Circuits (NACs). Optional Class A device wiring is available with the use of a module.

This life safety system features an attractive design that fits with any decor. Its distinctive doorfront offers a contemporary look that's available with red or silver finishes. All LED indicators and its large backlit display remain easy to see at all times.

The iO64 supports a wide range of accessories and related equipment, including:

- Signature Series intelligent modules, detectors, and bases
- R-Series remote annunciators
- option cards that expand system capacity and extend system capabilities.

Features

- Comes standard with one loop that supports up to 64 intelligent devices of any type and two Class B NACs.
- Supports Signature Series modules and detectors
- Form C for Alarm and Trouble, Form A for Supervisory
- Electronic addressing with automatic device mapping
- Optional Ethernet port for diagnostics, programming and variety of system reports
- Two programmable switches with LEDs and custom labeling
- Supports Genesis horn silence over two wires and UL 1971-compliant strobe synchronization
- Optional Class A wiring
- Supports up to eight serial annunciators, (LCD, LED-only, and graphic interface).
- Can use existing wiring for most retrofit applications
- Upload/download remotely or locally
- Two-level maintenance alert reporting
- Pre-alarm and alarm verification by point
- Adjustable detector sensitivity
- 4 x 20 character backlit LCD display

iO64 Intelligent Life Safety System



Application

The iO64 life safety system is a powerful intelligent solution for small to mid-sized buildings. Advanced analog technology delivers the benefits of flexible system installation, while a clean and easy-to-operate user interface makes panel operation and system maintenance quick and intuitive.

The smart choice

Signature Series electronic addressing eliminates the tedium of setting dipswitches, and automatic device mapping ensures that each device resides on the system at its correct location. Meanwhile, innovative programming features allow the system designer to customize powerful built-in features to precisely suit the needs of the building owner.

Flexibility built right in

Two fully-programmable front panel switch/LED combinations provide an added measure of flexibility. Their slide-in labels take the mystery out of custom applications, and present a clean finished appearance.

Perfect for retrofits

The iO64 is particularly well-suited to retrofit applications. All connections are made over standard wiring – no shielded cable required. This means that in most situations existing wiring can be used to upgrade a legacy control panel to iO-Series technology without the expense or disruption of rewiring the entire building.

Signals with a difference

iO64 NACs are configurable to fully support the advanced signaling technology of GE Genesis and Enhanced Integrity notification appliances. These devices offer precision synchronization of strobes to UL 1971 standards. For Genesis devices, enabling this feature allows connected horns to be silenced while strobes on the same two-wire circuit continue to flash until the panel is reset.

Clear-cut remote annunciation

Remote annunciation is a strong suit of the iO64. Up to eight annunciators can be installed on a single system. Compatible annunciators include a range of LED and LCD models that provide zone or point annunciation, as well as common control capabilities.

The iO64 also supports graphic annunciation with optional graphic annunciator interface modules. Each interface provides common control, indicators, and LED drivers. Consult the Ordering Information section for details.

A complete line of accessories

The iO64 life safety system is supported by a complete line of intelligent detectors, modules and related equipment. Consult the Ordering Information section for details.

Operation

The front panel provides an easy-to-use operator's interface, as well as all the necessary controls for front panel programming. A large back-lit 80-character LCD displays system status, event details, and programming prompts. Large tactile control buttons are easy to see in low light conditions, and bright multi-color LEDs offer at-a-glance status indication.

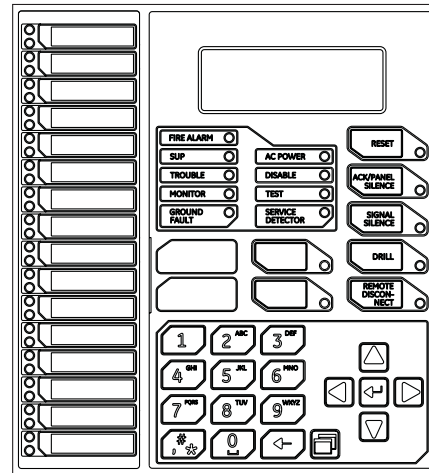

Control buttons

Button	Description
System Reset	Initiates a system reset.
ACK/Panel Silence	Silences the panel and remote annunciators during an active trouble, supervisory, or alarm event and acknowledges new event activations.
Signal Silence	<i>Alarm mode:</i> Silences active notification appliances. Pressing Signal Silence a second time turns NACs back on.
Drill	Initiates a drill confirmation. Pressing drill a second time turns off the drill function.
Remote Disconnect	<i>Dialer:</i> Disables or enables dialer. <i>Dialer set to modem only:</i> Disables or enables the common alarm relay.
Left arrow	<i>Display mode:</i> Moves the cursor to the left. <i>Menu mode:</i> Toggles between programming selections.
Right arrow	<i>Display mode:</i> Moves the cursor to the right. <i>Menu mode:</i> Retrieves a programming option's sub menu and toggles between a programming option's selections.
Up arrow	<i>Display mode:</i> Advances to the previous event. <i>Menu mode:</i> Moves the cursor up.
Down arrow	<i>Display mode:</i> Advances to the next event. <i>Menu mode:</i> Moves the cursor down.
Enter	<i>Display mode:</i> Displays selected event details. <i>Menu mode:</i> Retrieves a programming option's sub menu or jumps to the <i>Save</i> function in the menu. <i>Entry mode:</i> Enters the selected data into the system.
Cancel	<i>Display mode:</i> Exits the detailed information display. <i>Menu mode:</i> Exits the current menu level. <i>Entry mode:</i> Clears the current entry.
Menu	<i>Display mode:</i> Enters the menu mode <i>Menu mode:</i> Exits menu mode
Space	Enters a space, such as a space between words.
Alphanumeric keypad	<i>Entry mode:</i> Pressing a button once enters the number on the button. Pressing the button twice enters the secondary value.
Programmable buttons	These buttons can be programmed to control or enable/disable a device, zone, or Panel NAC. The buttons can be labeled with a slip-in insert.

System LEDs

LED	Description
FIRE ALARM	Red LED. Flashes when there is an active alarm event on any loop. On steady once acknowledged.
TROUBLE	Yellow LED. Flashes when there's a fault with a monitored circuit or system component or when a circuit is disabled. On steady once acknowledged.
SUP	Yellow LED. Flashes when there is an active supervisory event on any loop. On steady once acknowledged.
AC POWER	Green LED. On when the panel has AC power.
DISABLE	Yellow LED. Double-flashes when there is a disabled circuit, alarm relay, or remote annunciator.
GROUND FAULT	Yellow LED. On steady during an active ground fault.
TEST	Yellow LED. Flashes when performing an audible walk test. Steady indicates a silent test.
MONITOR	Yellow LED. Flashes when there is an active monitor event on any loop. On steady once acknowledged.
SERVICE DETECTOR	Yellow LED. Indicates that detector needs servicing.
SIGNAL SILENCE	Yellow LED. On steady indicates that NAC circuits are turned off but the panel is still in alarm.
REMOTE DISCONNECT	Yellow LED. On steady indicates that the dialer is disabled or that the alarm relay is enabled or disabled when the dialer is set to modem only.
DRILL	Yellow LED. Indicates that the panel is in drill.
RESET	Yellow LED. Indicates that the panel is resetting.
PANEL SILENCE	Yellow LED. Indicates that the panel has been silenced during an active trouble, supervisory, or alarm event and indicates that new event activations have been acknowledged.
USER KEYS	Yellow LED. Indicates the programmed key function is active.

Panel Operation Options

Language	English or French
Marketplace	U.S. or Canada
AC fail delay	<i>Off:</i> Off-premise notification of an AC power failure is immediate. <i>1 to 15 hours:</i> Delays the off-premise notification of an AC power failure by the time period selected.
Zone resound	<i>On:</i> NACs resound each time a device in the zone goes into alarm even if they were silenced <i>Off:</i> Inhibits the NACs from turning on again (after they were silenced) when a second device in the zone goes into alarm.
Reset inhibit after NACs turn on	<i>Off:</i> Panel reset is operational immediately. <i>1 minute:</i> Panel reset is inhibited for one minute.
Auto signal silence	<i>Off:</i> Allows immediate silencing of signals from an off-normal condition using the Signal Silence button <i>5 to 30 minutes:</i> Delays the silencing of signals from an off-normal condition by disabling the Signal Silence button for the time period selected.
Day start	Start time for daytime sensitivity
Night start	Start time for nighttime sensitivity
Date	<i>U.S.:</i> MM/DD/YYYY <i>Canada:</i> DD/MM/YYYY
Mapping	<i>Disabled:</i> Device mapping is not available <i>Enabled:</i> Device mapping is available
LCD banner	Banner text for line one and line two. Each line is capable of up to 20 characters.
Event notification	<i>Zone:</i> When a device is a member of a zone, only the zone information is sent to the LCD display, LEDs, printer, and dialer. <i>Zone/device:</i> Zone information is sent to the LCD display and LEDs. Device information is sent to the printer and dialer. <i>Device:</i> Only device information is reported.

Dimensions

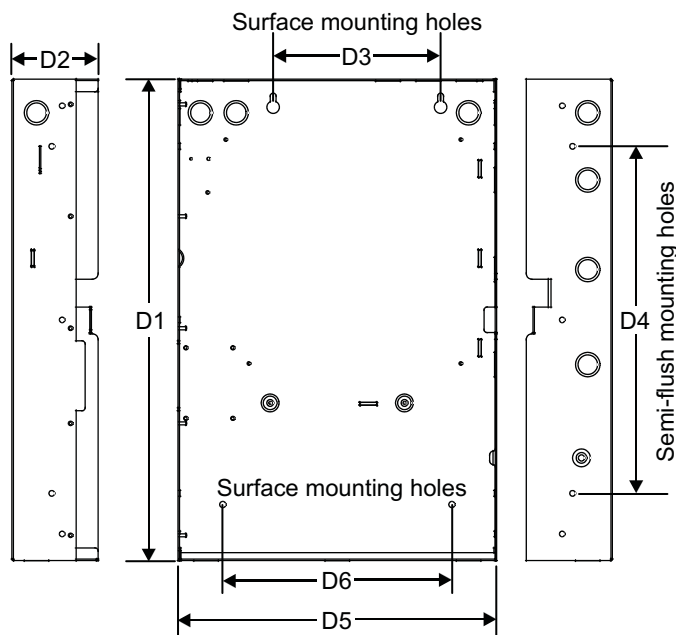

Panel dimensions, in (cm)

Model	D1*	D2	D3	D4	D5*	D6
iO64	21.50 (54.6)	3.85 (9.8)	7.5 (19.0)	15.5 (39.4)	14.25 (36.2)	10.25 (26.0)

* Add 1-1/2 in. (3.81 cm) to D1 and D5 dimensions for trim kit.

Programming

iO-Series life safety systems are simple to set up, yet also offer advanced programming features that put these small building panels into a class of their own. The auto programming feature quickly gets the panel operational using factory default settings. Basic zone and point settings can be programmed easily through the front panel interface, so the system is up and running in no time.

For more advanced system configuration and correlation groups programming, iO-Series systems interface to a PC running compatible iO-CU software. This option offers full system configuration in the familiar Windows® operating environment. Connection is typically made to a laptop through the panel's optional RS-232 communications port, which can also be used to connect a system printer.

Among the many advanced features of iO-Series control panels is the optional network card. This module provides a standard 10/100 Base T Ethernet® network connection that permits access to the control panel from any remote location with the correct communications protocols. The connection can be used to download to the panel from the iO-CU, or upload and view system reports using the iO-CU.

Available system reports include:

- Correlation groups
- Device maintenance
- Internal status
- System status
- Dialer
- Device details
- History
- System configuration
- Walk test

Wiring & Configuration

Notification appliance circuits (TB2)

The iO64 comes equipped with two notification appliance circuits. Each circuit can be individually configured for continuous, temporal, synchronized, and coded output.

Circuit Specifications	
Circuit Type	2 Class B, Class A optional when Class A card is installed. Each circuit is 2.5 amps.
Voltage	24 VFWR
Current	3.75A total (115/230 60hz) 3.0A total (230v 50hz) 2.5 A max per circuit
Impedance	26 Ω total, 0.35 μF max
EOLR	15 K Ω, ½ W

Class B wiring

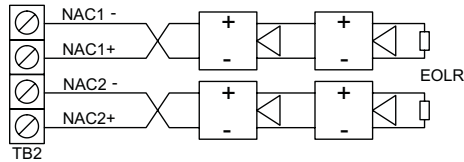

Marking indicates output signal polarity when the circuit is active. Polarity reverses when the circuit is not active. Wire notification appliances accordingly. Notification appliance polarity shown in active state.

Signature Device loop

The system provides one device loop circuit that can be used with any mix of Signature Series detectors and modules. The loop circuit is supervised for opens, shorts, and grounds.

Circuit Specifications	
Device loops	1 loop Class B, Class A optional when Class A card is installed. Supporting up to 64 device addresses.
Communication line voltage	Maximum 20 V peak-to-peek
Circuit current	0.5 A max
Circuit impedance	66Ω total, 0.5 μF, max
Isolators	64 maximum

Class B wiring

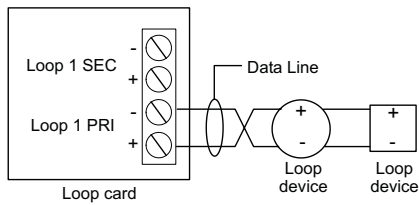

Class A wiring

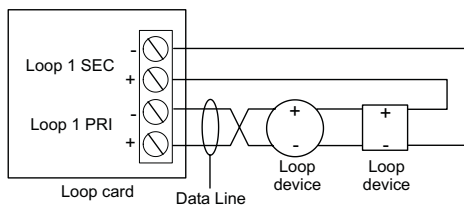

Alarm, trouble, and supervisory relay (TB3)

The trouble relay is normally-open, held closed, and opens on any trouble event or when the panel is de-energized. The supervisory relay is normally-open, and closes on any supervisory event. The alarm relay changes over on any alarm event.

Relay specifications

	Alarm	Trouble	Supervisory
Type	Form C		Form A
Voltage	24 VDC at 1 A resistive	24 VDC at 1 A resistive	

Relay circuits can only be connected to power-limited sources.

Auxiliary & Smoke power outputs (TB3)

The control panel provides two auxiliary power outputs which can be used for powering ancillary equipment such as remote annunciators and two wire smoke detectors. Aux 2 can be software selected to operate continuous. The circuit is supervised for shorts and grounds.

Note: For a complete list of devices that can be connected to this circuit, refer to the iO Series compatibility list (p/n 3101064).

Circuit specifications

Circuit voltage range	21.9 to 28.3 V
Resettable circuit (Aux power 2)	24 VDC nominal at 500 mA
Continuous circuit (Aux power 1)	24 VDC nominal at 500 mA. Use this circuit for powering two-wire smoke detectors.

Note: Any current above 0.5 amp connected to both Aux 1 and 2 will reduce the total available NAC power by that amount.

Annunciator loop (TB4)

The control panel provides a connection for up to eight serially driven and supervised remote annunciators.

Circuit specifications

Device loops	Class B (Style Y) or Class A (Style Z)
Circuit voltage	2.55 V
Circuit current	30 mA max
Circuit impedance	Up to 8 annunciators or 4000 feet

Class B

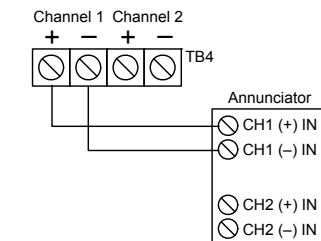

Class A

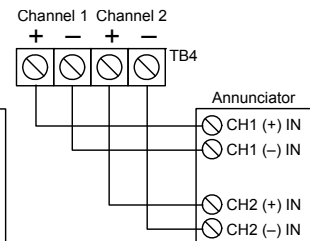

Option Cards

iO-Series panels are supported by a complete line of modules and related equipment that enhance performance and extend system capabilities. Option cards are easy to install and set up. They simply plug directly into the control panel main circuit board or are connected to it with a ribbon cable. After installation, terminals remain easily accessible for quick connection of field wiring. The cabinet provides ample room for wire routing, keeping wiring neat and easy to service at all times.

SA-CLA Class A Module

The SA-CLA card provides Class A capability for NAC, loop, and annunciator wiring. Its terminal block provides the wiring connection for NAC return wiring. The card is required for loop and annunciator Class A wiring even though this wiring does not return to the SA-CLA card. The SA-CLA is compatible with iO64 control panels only. iO500 panels are Class A ready. The SA-CLA is installed directly to the control panel circuit board using its plastic standoffs and plug connection.

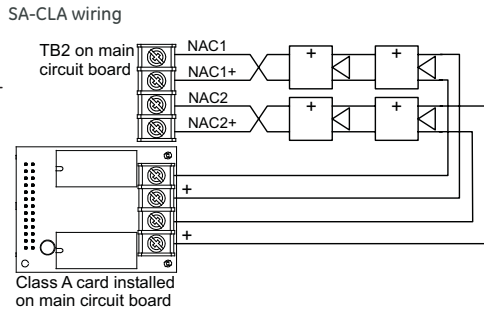

SA-CLA specifications

Operating voltage	24 VFWR
Operating current	2.5 A/circuit, 3.75A total (115/230 60hz) 3.0A total (230v 50hz)
Circuit impedance	26 Ω , 0.35 μ F, max
Terminal rating	12 to 18 AWG (0.75 to 2.5 sq mm)
Operating environment	
Temperature	32 to 120°F (0 to 49°C)
Humidity	0 to 93% RH, noncondensing at 90°F (32°C)

SA-ETH Ethernet Interface Card

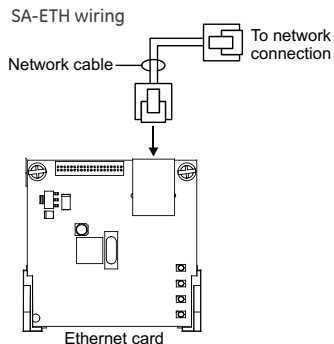

The SA-ETH card provides a standard 10/100 Base T Ethernet network connection for connecting to an intranet, a local network, or the Internet. The card can be used to download configuration programming from the iO-CU to the panel over the network.

The Ethernet card is installed on the plastic assembly and connects to the main circuit board via a ribbon cable.

SA-ETH specifications

Ethernet	10/100 Base T
Operating environment	
Temperature	32 to 120°F (0 to 49°C)
Humidity	0 to 93% RH, noncondensing at 90°F (32°C)

SA-232 RS-232 interface

The SA-232 card provides an RS-232 interface with iO-Series panels. It can be used for connecting a printer to the control panel to print system events. The card also can be used for connecting a computer to download a configuration program from the iO-CU to the control panel.

SA-232 wiring

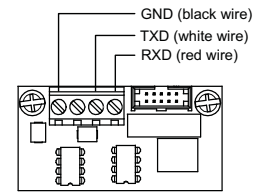

The RS-232 card is installed on the plastic assembly and connects to the main circuit board via a ribbon cable.

SA-232 specifications

Operating voltage	Standard EIA-232
Terminal rating	12 to 18 AWG (0.75 to 2.5 sq mm)
Operating environment	
Temperature	32 to 120°F (0 to 49°C)
Humidity	0 to 93% RH, noncondensing at 90°F (32°C)

SMK Smoke Power Converter

The SMK Smoke Power Converter Module provides a backup power source for two-wire smoke circuits connected to a Signature data circuit. The SMK monitors the operating power from the power supply. When power begins to degrade, the SMK provides the necessary operating voltage to the two-wire smoke detection circuits.

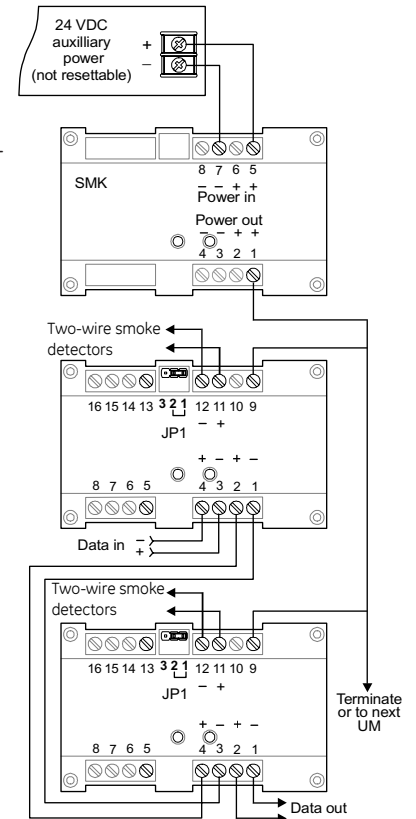

SMK specifications

Input voltage	21.9 to 28.3 VDC (not resettable)
Output voltage	24 VDC nom. at 200 mA, max., special applications
Ground fault impedance	10 k ohm
Operating environment	
Temperature	32 to 120°F (0 to 49°C)
Humidity	0 to 93% RH, noncondensing at 90°F (32°C)
Storage temperature	-4 to 140°F (-20 to 60°C)
Compatible electrical boxes	North American 4 inch square x 2-1/2 in. (64 mm) deep 2 gang box or Standard 4 in. square box 1-1/2 in. (38 mm) deep
Wire size	14, 16, or 18 AWG wire (1.5, 1.0, or 0.75 sq. mm) (Sizes 16 and 18 AWG are preferred)

SA-DACT Dialer

The SA-DACT provides communications between the control panel and the central station over a telephone line system. It transmits system status changes (events) to a compatible digital alarm communicator receiver over the public switched telephone network. The dialer is capable of single, dual, or split reporting of events to two different account and telephone numbers. The modem feature of the SA-DACT can also be used for uploading and downloading panel configuration, history, and current status to a PC running the iO-CU.

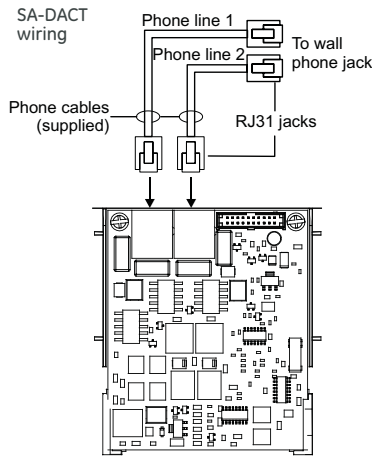

The dialer phone lines connect to connectors on the dialer's main circuit board. Phone line 1 connects to connector J4 and phone line 2 connects to connector J1.

The SA-DACT queues messages and transmits them based on priority (alarm, supervisory, trouble, and monitor). Activations are transmitted before restorations.

The SA-DACT is installed on the plastic assembly and connects to the main circuit board via a ribbon cable.

Specifications

Device loops	1 loop Class B, Class A optional, supporting up to 64 device addresses
Notification appliance circuits	2 Class B, Class A optional, 2.5 amps each
Power supply	3.75 A FWR total at 120/230 VAC 60 Hz 3.0 A FWR total at 230 VAC 50 Hz 0.5 amps aux power
NAC Operating voltage	24 VDC. NAC minimum voltage: 19.5 VDC @ 20.4 V battery voltage
SLC Loop operating voltage	20 V peak-to-peak
Primary power	120 VAC, 60 Hz, 230 VAC 50-60 Hz
Aux Power 1 (Continuous circuit)	24 VDC nominal at 500 mA. A SMK module is required when using the SIGA-UM module to support two-wire smoke detectors.
Aux Power 2 (Resettable circuit)	24 VDC nominal at 500 mA.
Auxiliary output	19 to 25.7 VDC
Base panel current draw	Standby: 155 mA Alarm: 204 mA
Battery placement	iO64 cabinets accommodate up to 10 A/H batteries. Use an external cabinet for larger battery sizes.

SA-DACT specifications	
Phone line type	One or two loop-start lines on a public, switched network
Phone line connector	RJ-31/38X (C31/38X)
Communication formats	Contact ID (SIA DC-05)
Operating environment	Temperature 32 to 120°F (0 to 49°C) Humidity 0 to 93% RH, noncondensing at 90°F (32°C)

Compatible DACRs		
Receiver	Models	Formats
Ademco	685	Contact ID
FBI	CP220	Contact ID
Osborne-Hoffman	OH 2000	Contact ID
Radionics	D6600	Contact ID
Silent Knight	9800	Contact ID
Sur-Gard	SG-MLR1, MLR2	Contact ID

Batteries	Batteries must be sealed lead acid type only. Maximum charging capacity = 26 Ah.
Loop circuit	Maximum loop resistance: 66 Ω. Maximum loop capacitance: 0.7 μF. Style 4, 6, and 7 wiring. 64 isolators maximum
Loop circuit max detector standby current	1.5 mA (see the UL and ULC compatibility list for your panel for the maximum quantity of detectors per circuit)
Compatibility ID	100
Alarm contact	Form C 24 VDC @ 1 A (resistive load)
Trouble contact	Form C 24 VDC @ 1 A (resistive load)
Supervisory contact	Form A 24 VDC @ 1 A (resistive load)
Environmental	Temperature: 0 to 49°C (32 to 120°F). Humidity: 0 to 93% RH, noncondensing
Terminal rating	All terminals rated for 12 to 18 AWG (0.75 to 2.5 sq mm)
Serial communications	Voltage: 2.55 V. Current: 30 mA max
Remote annunciator	8 drops max, RS-485 Class B, Class A
Input zones	16 max.
Agency Listing	UL, CSFM and ULC

Ordering Information

Part	Description
iO64 Intelligent Single Loop Analog Systems	
IO64G	1 Loop System, 64 point capacity, 2 Class B NACs, Gray door, surface mount enclosure, 115VAC transformer, English.
IO64GD	1 Loop System, 64 point capacity, 2 Class B NACs, 2 Line Dialer, Gray door, surface mount enclosure, 115VAC transformer, English.
IO64R	1 Loop System, 64 point capacity, 2 Class B NACs, Red Door, surface mount enclosure, 115VAC transformer, English.
IO64RD	1 Loop System, 64 point capacity, 2 Class B NACs, 2 Line Dialer, Red Door, surface mount enclosure, 115VAC transformer, English.
iO64G-2	1 Loop System, 64 point capacity, 2 Class B NACs, Gray door, surface mount enclosure, 230VAC transformer, English.
iO64R-2	1 Loop System, 64 point capacity, 2 Class B NACs, Red door, surface mount enclosure, 230VAC transformer, English.
iO64GL	1 Loop System, 64 point capacity, 2 Class B NACs, 16-zone LED display, grey door, surface mount enclosure, 115VAC transformer, English
iO64GL-F	1 Loop System, 64 point capacity, 2 Class B NACs, 16-zone LED display, grey door, surface mount enclosure, 115VAC transformer, Canadian French
SA-TRIM1	Flush mount trim, black

Option Cards	
SA-DACT	Dual Line Dialer/Modem, supports 4/2 and Contact ID, mounts in cabinet on base plate.
SA-232	Serial Port (RS-232), for connection to printers & computers, mounts in cabinet to base plate
SA-ETH	Ethernet Port, Slave, mounts in cabinet on base plate.
SA-CLA	Class A adapter module. Provides Class A capacity on NACs. Mounts in cabinet on main board.
D16L-iO-1	LED Annunciator module, two LEDs per zone, 16 zones (4 max programmable for sup). Mounts in cabinet to left of LCD display for zones 1-16.

Remote Annunciators (refer to Data Sheet 85005-0128)

LCD Remote Annunciators	
RLCD	Remote Annunciator, 4X20 LCD & Common Indicators for displaying system status, mounts 4" Square electrical box, gray housing.
RLCD-R	Remote Annunciator, 4X20 LCD & Common Indicators for displaying system status, mounts 4" Square electrical box, red housing.
RLCD-C	Remote Annunciator, 4X20 LCD, Common Indicators & Common Controls for displaying system status, mounts 4" Square electrical box, gray housing.
RLCD-CR	Remote Annunciator, 4X20 LCD, Common Indicators & Common Controls for displaying system status, mounts 4" Square electrical box, red housing.

For French common control, add suffix F to model number.

LED Remote Annunciators & Expander	
RLED-C	Remote Annunciator, Common Indicators for displaying system status, common controls & 16 groups w/2 LEDs each for zone display, mounts to standard 4" Square electrical box, gray housing.
RLED-CF	Remote Annunciator, Common Indicators for displaying system status, common controls & 16 groups w/2 LEDs each for zone display, mounts to standard 4" Square electrical box, gray housing, French.
RLED-CR	Remote Annunciator, Common Indicators for displaying system status, common controls & 16 groups w/2 LEDs each for zone display, mounts to standard 4" Square electrical box, red housing.
RLED24	Remote Annunciator Zone expander, 24 groups of 2 LEDs each for display of alarm and trouble. Each with custom label area. Mounts to standard 4" electrical box, gray housing.
RLED24R	Remote Annunciator Zone expander, 24 groups of 2 LEDs each for display of alarm and trouble. Each with custom label area. Mounts to standard 4" electrical box, red housing.

Graphic Annunciator Drivers	
GCI	Graphic Annunciator Driver, provides outputs for common indicators and 32 alarm/supv zones as well as inputs for common switches. Provided with a snap track for mounting in custom graphic enclosures.

Remote Annunciator Cabinets & Accessories	
RA-ENC1	Remote Annunciator Enclosure, key locked with plexiglass window for one RLCD(C) or RLED(C).
RA-ENC2	Remote Annunciator Enclosure, key locked with plexiglass window with space for 2 of either RLCDx, RLEDx or RLED24.
RA-ENC3	Remote Annunciator Enclosure, key locked with plexiglass window with space for 3 of either RLCDx, RLEDx or RLED25.
RKEY	Keyswitch, single gang, provides key operated enable or disable of common controls on RLCD or RLED units.
LSRA-SB	Surface Mount Box - for R Series single units.

Programming Tools	
iO-CU	EST Series configuration and diagnostics utility.

Continued...

U.S.
T 888-244-9979
F 866-503-3996

Canada
T 519 376 2430
F 519 376 7258

Asia
T 852 2907 8108
F 852 2142 5063

Australia
T 61 3 9259 4700
F 61 3 9259 4799

Europe
T 32 2 725 11 20
F 32 2 721 86 13

Latin America
T 305 593 4301
F 305 593 4300

www.gesecurity.com

Windows is a registered trademark
of Microsoft Corporation.
Ethernet is a registered trademark of Xerox.

© 2008 General Electric Company
All Rights Reserved

Analog Addressable Devices & Accessories

Part Number	Description	Ship wt.
Intelligent Detectors & Bases		
SIGA-HFS	Intelligent Fixed Temperature Heat Detector - UL/ULC Listed	
SIGA-HRS	Intelligent Fixed Temperature/Rate-of-Rise Heat Detector - UL/ULC Listed	
SIGA-IPHS	Intelligent 4D Multisensor Detector - UL/ULC Listed	
SIGA-IPHSB	Intelligent 4D Multisensor Detector (Black) - UL/ULC Listed	0.5 (0.23)
SIGA-PHS	Intelligent 3D Multisensor Detector - UL/ULC Listed	
SIGA-PS	Intelligent Photoelectric Detector - UL/ULC Listed	
SIGA-IS	Intelligent Ionization Detector - UL/ULC Listed	
SIGA-SD	Intelligent SuperDuct Detector	2.4 (1.1)
SIGA-SB	Detector Mounting Base	
SIGA-SB4	4-inch Detector Mounting Base c/w SIGA-TS Trim Skirt	
SIGA-RB	Detector Mounting Base w/Relay	
SIGA-RB4	4-inch Detector Mounting Base /w Relay c/w SIGA-TS Trim Skirt	0.2 (0.09)
SIGA-IB	Detector Mounting Base w/Fault Isolator	
SIGA-IB4	4-inch Detector Mounting Base w/ Fault Isolator c/w SIGA-TS Trim Skirt	
SIGA-LED	Remote Alarm LED	
SIGA-AB4G	Audible (Sounder) Base	0.3 (0.15)
SIGA-TS4	Trim Skirt (supplied with 4-inch bases)	0.1 (.04)
Modules		
SIGA-CC1	Single Input Signal Module (Standard Mount)	0.5 (0.23)
SIGA-MCC1	Single Input Signal Module (UIO Mount)	0.18 (0.08)
SIGA-CC1S	Synchronization Output Module (Standard Mount)	0.5 (0.23)
SIGA-MCC1S	Synchronization Output Module (UIO Mount)	0.18 (0.08)
SIGA-CC2	Dual Input Signal Module (Standard Mount)	0.5 (0.23)
SIGA-MCC2	Dual Input Signal Module (UIO Mount)	0.18 (0.08)
SIGA-CR	Control Relay Module (Standard Mount)	0.4 (0.15)
SIGA-MCR	Control Relay Module (UIO Mount)	0.18 (0.08)
SIGA-CRR	Polarity Reversal Relay Module (Standard Mount)	0.4 (0.15)
SIGA-MCRR	Polarity Reversal Relay Module (UIO Mount)	0.18 (0.08)
SIGA-RM1	Riser Monitor Module (Standard Mount)	0.5 (0.23)
SIGA-MRM1	Riser Monitor Module (Plug-in)	0.18 (0.08)
SIGA-IO	Input/Output Module (Standard Mount)	0.34 (0.15)
SIGA-MIO	Input/Output Module (Plug-in)	0.22 (0.10)
SIGA-MAB	Universal Class A/B Module (Plug-in)	0.18 (0.08)
SIGA-CT1	Single Input Module	0.4 (0.15)
SIGA-CT2	Dual Input Module	0.4 (0.15)
SIGA-MCT2	Dual Input Plug-in (UIO) Module	0.1 (0.05)
SIGA-IM	Fault Isolator Module	.5 (.23)
SIGA-MM1	Monitor Module	0.4 (.15)
SIGA-WTM	Waterflow/Tamper Module	0.4 (.15)
SMK	Smoke Power Converter Module	0.4 (0.15)
SIGA-UIO2R	Universal Module Board w/Riser Inputs - Two Module Positions	0.32 (0.15)
SIGA-UIO6R	Universal Module Board w/Riser Inputs - Six Module Positions	0.62 (0.28)
SIGA-UIO6	Universal Module Board - Six Module Positions	0.56 (0.25)
Accessories		
CTM	City Tie Module. Provides connection to a local energy fire alarm box.	0.6 (0.3)
RPM	Reverse Polarity Module	3.0 (1.36)
BC-1	Battery Cabinet. 14.0" x 18.25" x 7.25". Holds up to 2 12V24A batteries.	50.0 (22.7)
BC-1R	Battery Cabinet - Red. 14.0" x 18.25" x 7.25". Holds up to 2 12V24A batteries.	50.0 (22.7)
MFC-A	Multifunction Fire Cabinet, 8" x 14" x 3.5" - RED.	20.6 (9.4)
PT-1S	System Printer - Desktop style.	36.6 (16.6)

